

Hot Air Nozzles

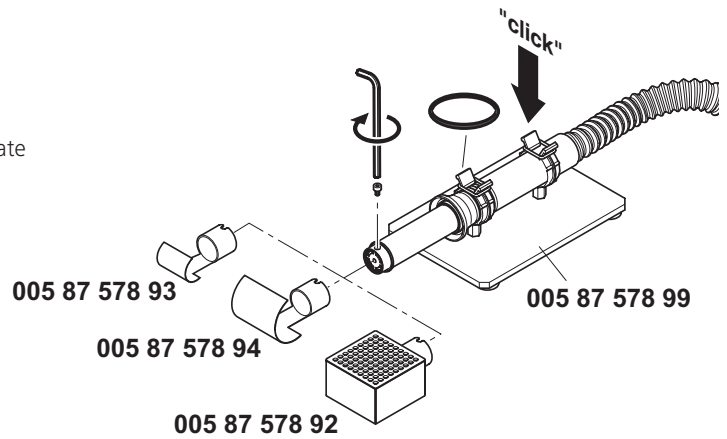

■ The ND and NQ nozzles have an integrated pre-heating plate for pre-heating components by means of contact heat. Air outlet slots are located around the plate with a width of approx. 1 mm for the hot air.



Hot air nozzles for HAP 3000 (WHA 3000P / V), HAP 2 (WHA 2000) and HAP 3 (WHA 700, WHA 300)

Order-no.	Model	Description	Diameter Ø	
T005 87 368 81	NR04	Round nozzle, without vacuum	Ø 2,5 mm	
T005 87 368 67	NR05	Round nozzle, without vacuum	Ø 4,0 mm	
T005 87 368 70	NR10	Round nozzle, without vacuum	Ø 7,0 mm	
T005 87 507 70	NRV07	Hot air nozzle with vacuum for small components	Ø 7,0 mm	
T005 87 507 72	NRV10	Hot air nozzle with vacuum for small components	Ø 10,0 mm	
T005 87 507 74	NRV12	Hot air nozzle with vacuum for small components	Ø 12 mm	
T005 87 368 82	NR02	Round nozzle, bent without vacuum	Ø 1,7 mm x 45°	
T005 87 507 65	NR06	Round nozzle, bent without vacuum	Ø 6,0 mm x 45°	
T005 87 368 83	DR05	Dual nozzle round, without vacuum	2 x Ø 2,5 mm	

2 sides heated (Type ND, Width X = heated side)

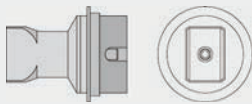
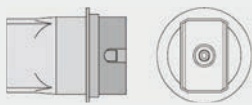

Order-no.	Model	Description	Length X	Width Y	
T005 87 368 43	ND05	Hot air nozzle, 2 sides heated	10,7 mm	10,7 mm	
T005 87 368 42	ND 10	Hot air nozzle, 2 sides heated	14,0 mm	10,0 mm	
T005 87 368 41	ND 15	Hot air nozzle, 2 sides heated	19,0 mm	12,0 mm	
T005 87 368 40	ND 20	Hot air nozzle, 2 sides heated	21,5 mm	14,8 mm	
T005 87 369 32	ND SK535/A	Hot air nozzle, without edge for thin components	8,5 mm	20,0 mm	
T005 87 369 33	ND SK535/B	Hot air nozzle, without edge for thin components	10,5 mm	20,0 mm	
T005 87 507 34	ND SK699	Hot air nozzle, without edge for thin components	12,5 mm	20,0 mm	
T005 87 369 34	ND SK535/C	Hot air nozzle, without edge for thin components	14,0 mm	20,0 mm	

Hot Air Nozzles

Four sides heated (Type NQ)

Order-no.	Model	Description	Length X	Width Y	
T005 87 368 39	NQ05	Hot air nozzle, 4 sides heated	10,7 mm	10,7 mm	
T005 87 368 38	NQ15	Hot air nozzle, 4 sides heated	14,5 mm	10,0 mm	
T005 87 368 18	NQ10	Hot air nozzle, 4 sides heated	14,8 mm	14,8 mm	
T005 87 368 37	NQ20	Hot air nozzle, 4 sides heated	15,5 mm	13,0 mm	
T005 87 368 14	NQ25	Hot air nozzle, 4 sides heated	18,0 mm	18,0 mm	
T005 87 507 21	NQ30	Hot air nozzle, 4 sides heated	17,5 mm	23,5 mm	
T005 87 368 07	NQ35	Hot air nozzle, 4 sides heated	20,5 mm	20,5 mm	
T005 87 368 80	NQ	Hot air nozzle, 4 sides heated	24,0 mm	12,0 mm	
T005 87 368 04	NQ40	Hot air nozzle, 4 sides heated	26,0 mm	26,0 mm	
T005 87 368 33	NQ45	Hot air nozzle, 4 sides heated	31,3 mm	31,3 mm	
T005 87 368 91	NQ50	Hot air nozzle, 4 sides heated	36,0 mm	36,0 mm	
T005 87 368 90	NQ55	Hot air nozzle, 4 sides heated	43,0 mm	43,0 mm	

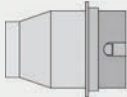
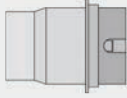
4 sides heated (Type NQ) continuation

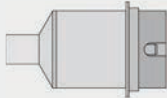
Order-no.	Model	Description	Length X	Width Y	
T005 87 507 41	NQT 10	Hot air nozzle, 4 sides heated, without protruding edge for thin components	14,8 mm	14,8 mm	
T005 87 507 42	NQT25	Hot air nozzle, 4 sides heated, without protruding edge for thin components	18,0 mm	18,0 mm	
T005 87 507 39	NQT	Hot air nozzle, 4 sides heated, without protruding edge for thin components	22,0 mm	22,0 mm	
T005 87 368 75	NA 20	Measuring nozzle for calibration			

Special tips on request

Pre heating nozzle for HAP 3



Order-no.	Description
T005 87 578 92	Pre heating nozzle for HAP 3

Multi rest



Order-no.	Description
T005 15 048 99	Multi rest for nozzle NR, ND NQ

Rubber insert for CSF heads (spare)

Order-no.	Description	
T005 87 137 99	Ø 4,5 mm, 10 pieces	
T005 87 137 98	Ø 10,0 mm, 10 pieces	